

<b>DATA SHEET</b> N° DS/003	<b>TRASP SYSTEM</b> 300 SERIES SNAP-ON SLEEVES	REV: 6
		DATA: 10/04/98

**DRAWING**

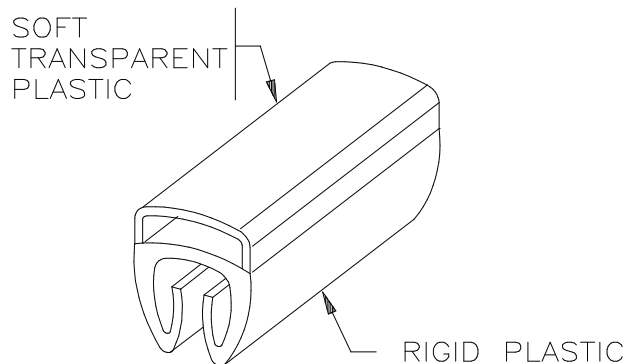

**ITEMS OF REFERENCE**

301 - 302 - 303 - 304

**GENERAL CHARACTERISTICS**

It allows to make the markings ready for use even once the electrical connection has been made.

**CHARACTERISTICS OF THE MATERIAL**

TYPE OF MATERIAL	RIGID P.V.C. - SOFT P.V.C.
COLOR	WHITE (RIGID PART)    TRANSPARENT (SOFT PART)
TEMPERATURE RANGE	- 50+ 80 °C ( '-58 ÷ +176 °F)
FIRE RESISTANCE	CLASS VO ACCORDING TO UL - 94
RESISTANCE TO WATER	☺
RESISTANCE TO OILS	☺
RESISTANCE TO DUST	☺
RESISTANCE TO ACIDS	☺
TOXIC MATERIALS, ABSENCE OF	PCB, PCT, PBB, PBDO, VC ( MAX. 1 ppm )

**CUT LENGTH MM.:** 10 - 15 - 23 - 30

**CUT LENGTH INCH.:** 0.39 - 0.59 - 0.91 - 1.18

ITEMS	CABLE EXT. DIAMETER (MM ÷ INCH.)	NO. OF PIECES PER PACK			
		10	15	23	30
301	2÷3.5 0.079÷0.138	1000	1000	500	500
302	2.8 ÷ 5 0.110 ÷ 0.197	1000	1000	500	500
303	5 ÷ 8 0.197 ÷ 0.315	500	500	200	200
304	8 ÷ 10 0.315 ÷ 0.394	500	500	200	200

**NOTES:**

<b>PREPARED:</b> Cazzulo Paola	<b>CHECK., APPROV.:</b> SA:	<b>DATE:</b> 10/04/1998	<b>SUBJECT MATTER OF REVISION:</b> ADJUSMENT TO NEW PRODUCT SIZE	<b>PAG:</b> 1 of 1
-----------------------------------	--------------------------------	----------------------------	---	-----------------------